

# **ON BOARD COMPUTER OF THE CUBSAT**

## Table of contents

6.1 – OBC’S ROLE .....	2
6.2 COMPOSITION OF THE OBC.....	3
6.2.1 Hardware.....	3
6.2.1.1 Criteria .....	3
6.2.1.2 Process Selection .....	4
6.2.2 Software .....	4
6.3 ARCHITECTURE OF THE OBC .....	5
6.3.1 Presentation of MSP 430 .....	5
6.3.2 Presentation of ARM Cortex-M3 .....	7
6.3.3 Proposed OBC architecture .....	9

## 6.1 – OBC’S ROLE

The onboard computer (OBC), provided by the control board, manages all the tasks taking place within the satellite. It also provides the storage and transfer of data to the transmitter. Indeed, its function is to interpret the orders from Earth, treat and return the results. It also monitors and maintains the proper functioning of the system.

An OBC enables the communication between the different subsystems :

An electrical power system (EPS) supplied by solar panels; A payload (e.g. beacon transmitter or camera) with its control unit; An attitude determination and control system (ADCS); A radio frequency (RF) communication subsystem; A memory module generally associated with the OBC.

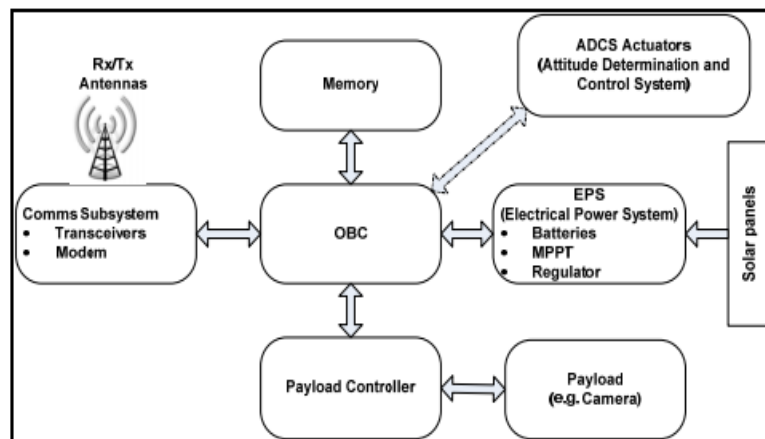

Figure 1 : Basic CubeSat Architecture (Source : [http://digitalknowledge.cput.ac.za/jspui/bitstream/11189/1307/1/Lumbwe\\_T\\_Final2013.pdf](http://digitalknowledge.cput.ac.za/jspui/bitstream/11189/1307/1/Lumbwe_T_Final2013.pdf))

The Electronic card of the OBC imposes the type of data bus and their location on the other cards of the CubeSat.

Here are the different specific roles assigned to the OBC:

- deployment of antennas and activation of other subsystems
- acquisition, recording and repatriation measures
- transmission of a time reference in the entire system
- activation / deactivation of other subsystems depending on certain conditions
- restart a subsystem in the event of short-circuit
- management and configuration of payloads (xEPS and D-STAR)
- receiver and transmitter configuration
- decoding remote controls
- remote scheduling to run
- encoding of telemetry

## 6.2 COMPOSITION OF THE OBC

OBC is the brain of the CubeSat. It is based on a microcontroller connected to the subsystems via a serial data bus and HW device.

A real time OS (RTOS) that manages all the software applications, starts the microcontroller and provides the flight software CubeSat (FSW).

### 6.2.1 Hardware

For the purpose of developing a CubeSat OBC, we have to answer to this following question : *which microcontroller should be considered the best and why? What requirements and specifications can be considered ideal for a particular microcontroller when compared to others in its range in order to develop the OBC around it?*

#### 6.2.1.1 Criteria

To select the best microcontroller, we have to take care about many things to avoid some issues.

- **Power consumption**

A low power scheme is the major requirement in satellite systems due to the fact that electrical power is extremely limited, particularly in CubeSats where a total power budget of 1W is available for a 1U and 5W for a 3U due to the minimal external surface area covered by solar panels. In addition to a low power consumption figure, the microcontroller should accommodate a feature whereby power can be saved by disabling peripherals which are not in use during a particular phase of the mission. It is common for microcontrollers to feature different modes of operation and use more than one clock source, allowing various operating modes and saving on power consumption.

- **Température**

The variations of temperature in LEO are quite significant. When the CubeSat orbits the sunny side of Earth, the surface of the satellite gets very warm and reaches temperatures up to 150°C. Similarly, when covering the zone of eclipse, the temperature can drop as low as -150°C (Koskienen et al., 1999). These extreme changes in temperature can cause damage to electronic components inside the CubeSat. For this reason, all the hardware components of the OBC to be implemented should be rated for an operating range between -40°C and 85°C which is the standard for industrial electronic equipment.

- **Operating voltage**

The EPS (used to supply, transmit and use electric power) in a CubeSat normally provides an unregulated bus voltage varying between 6V and 8.3V. In order to avoid the implementation of several voltage regulators (buck or boost) which may add to the weight, size and

complexity of subsystems onboard the CubeSat, most of the active components including the OBC's microcontroller, should be chosen to operate at or below a value of 3.3V.

- **I/O and serial bus compatibility**

The variety of I/Os (digital and analogue) available on the microcontroller are necessary in terms of connectivity. Being able to interface the final OBC prototype with all other subsystems within the CubeSat is mandatory and is directly related to the microcontroller chosen to implement the design. The data transfer between subsystems is made possible by the OBC's microcontroller's integrated serial interfaces (UART, I2 C or UART). Selecting a microcontroller which possesses one or more of each of the serial interfaces is highly recommended since each of them is constrained by their data transfer rates and data or address bus sizes (Castoulis, 2005).

### 6.2.1.2 Process Selection

Depending on the tasks to be completed and how fast the operations need to be accomplished, microcontrollers are available from different manufacturers in variants supporting 8-bit, 16-bit and 32-bit word length.

8-bit and 16-bit architectures were favoured in CubeSat technology because many of the embedded and real time applications at the time were not critically dependant on memory, power or speed and the amount of data to handle was sufficient.

With time, more products and applications started to require increased processing capability. It became clear that a migration from 8 and 16-bit to 32-bit core architecture was necessary, although the complexity remained an issue (Khan, 2008) that is why for the moment there is more CubeSat's OBC developed with a microcontroller 16-bit.

Supposition: A Belgian team who build OUFTI CubeSat put inside it two OBCs in order to prevent problems. In fact, if the OBC that they developed, has a problem, the OBC that they bought, will take its place.

### 6.2.2 Software

The software component controls the processor, its operation and control functionality.

A real-time operating system in English for RTOS real-time operating system (pronounced Are-toss) is a multitasking operating system for real-time applications.

RTOS such as: FreeRTOS (Advantage: free, open source, lightweight, reliable, compatible with MSP 430 microcontroller type). This is the OS used by the Liege University students for their CubeSat Oufiti.

Warning: OS must support the microcontroller

## 6.3 ARCHITECTURE OF THE OBC

<b>Modèle</b>	EFM32GG880	MSP430F1611	AT91M55800A	AT91SAM7A3	AT91SAM7A1
<b>Utilisé dans</b>	CubeSense	SwissCube	SwissCube	AAUSAT3	Nanomind
<b>Fabricant</b>	Energy Micro	Texas Instruments	Atmel	Atmel	Atmel
<b>Processeur</b>	Cortex-M3	16-bit RISC	ARM7TDMI	ARM7TDMI	ARM7TDMI
<b>Fréquence</b>	48 MHz	8 MHz	33 MHz	60 MHz	40 MHz
<b>Finesse de gravure</b>	0,18 µm	0,35 µm	0,35 µm	0,18 µm	0,35 µm
<b>Températures</b>	-40 °C / 80 °C	-40 °C / 80 °C	-40 °C / 80 °C	-40 °C / 80 °C	-40 °C / 80 °C
<b>Puissance</b>	36,5 mW	8,7 mW	216 mW	231 mW	605 mW
<b>Performance</b>	60 DMIPS	N/A	31 DMIPS	57 DMIPS	38 DMIPS

Figure 2: Characteristics of microcontrollers already used in CubeSat project (Source: <http://space.epfl.ch/files/content/sites/space/files/Bulletin%20-%20D%C3%A9veloppement%20d'un%20micro-ordinateur...%20-%2003.10.2014>)

### 6.3.1 Presentation of MSP 430

Using a MSP430 microcontroller-type (manufactured by Texas Instruments) is widespread for CubeSat. This microcontroller is known for combining high performance with low power consumption, making it the ideal choice for developing embedded systems where power consumption must be kept to a minimum, as in the case of the OBC the CubeSat (Albus and al., 2009).

Here are the features of MSP430:

- 16-Bit RISC architecture.
- Low power range of 1.8 to 3.6V
- Very low consumption.
- Switch the low-power mode to active mode in less than 6ms.
- 12-Bit ADC.
- 2 DAC.
- A 16-Bit Timer.
- Timer B 16-Bit.
- Serial communication interface (USART0) works in asynchronous USART or synchronous I2C or SPI.
- Serial communication interface (USART1) works in asynchronous USART or synchronous SPI
- 8K of RAM and 1Mo Flash (no external memory bus which would effectively access RAM / ROM external memory)

Operating mode:

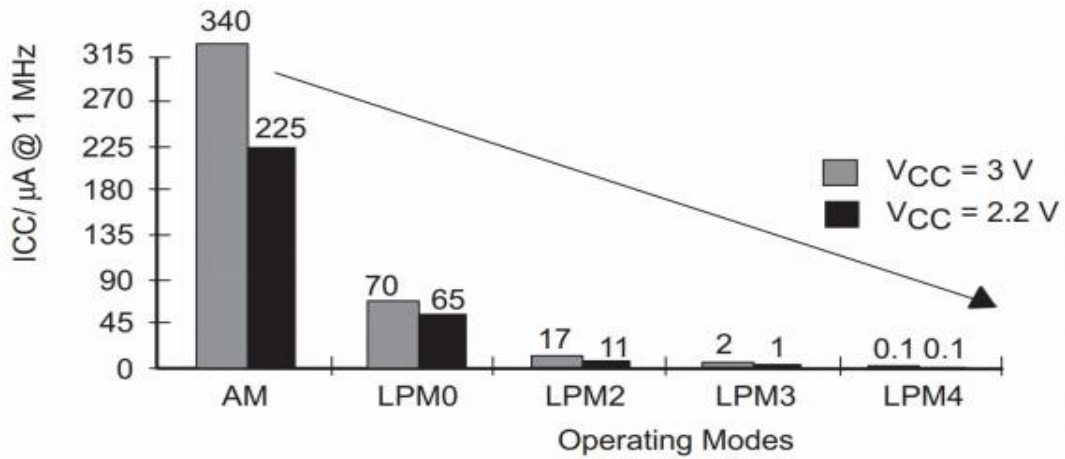

Figure 3: Operating mode of MSP 430 (Source: <http://www.ti.com/lit/ug/slau049f/slau049f.pdf>)  
 ICC: Individual Current Consumption AM: Active Mode LPM: Low-Power Mode

MSP 430 Architecture:

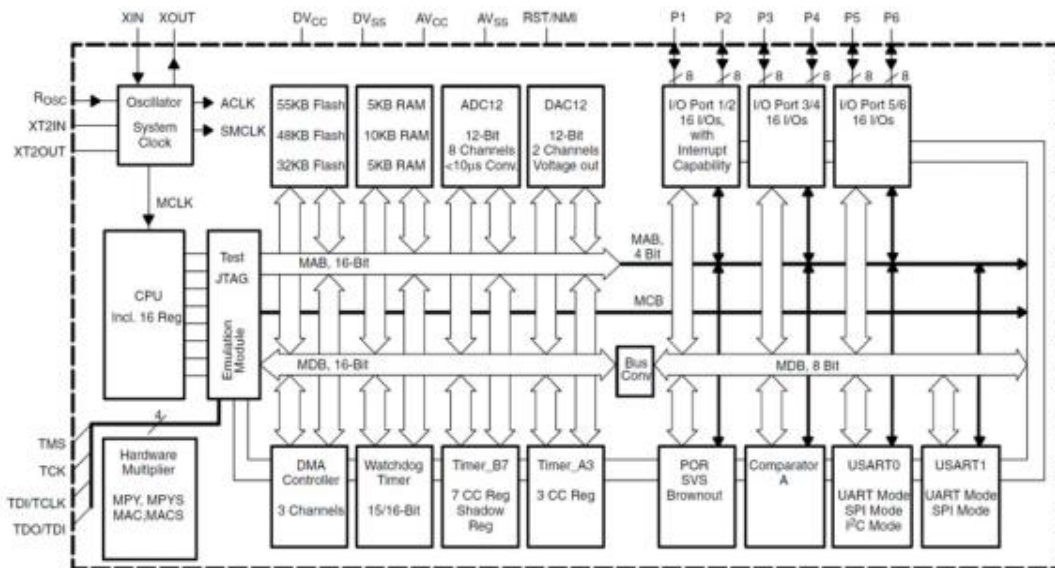

Figure 4: MSP 430 Architecture (Source: <http://www.ti.com/lit/ug/slau049f/slau049f.pdf>)

### 6.3.2 Presentation of ARM Cortex-M3

Using a ARM Cortex-M3 microcontroller-type (manufactured by Energy Micro) is widespread for CubeSat. This microcontroller is known for combining high performance (better than MSP 430 microcontroller-type) with low power consumption, making it the ideal choice for developing embedded systems where power consumption must be kept to a minimum.

Here are the features of MSP430:

- 18 x 32-bit registers
- Excellent compiler target
- Reduced pin count requirements
- Efficient interrupt handling
- Power management
- Efficient debug and development support features
- Breakpoints, Watchpoints,
- Flash Patch support
- Instruction Trace
- Strong OS support
- User/Supervisor model
- OS support features
- Designed to be fully programmed in C (even reset, interrupts and exceptions)
- ARMv7M Architecture
- No Cache - No MMU
- Debug is optimized for microcontroller applications
- Vector table contains addresses, not instructions
- DIV instruction
- Interrupts automatically save/restore state
- Exceptions programmed in C (No Coprocessor 15 - All registers are memory-mapped)
- Interrupt controller is part of Cortex-M3 macrocell
- Fixed memory map
- Bit-banding
- Non-Maskable Interrupt (NMI)
- Only one processor status reg
- Thumb-2 processing core
- Mix of 16 and 32 bit instructions for very high code density
- Gives complete Thumb compatibility

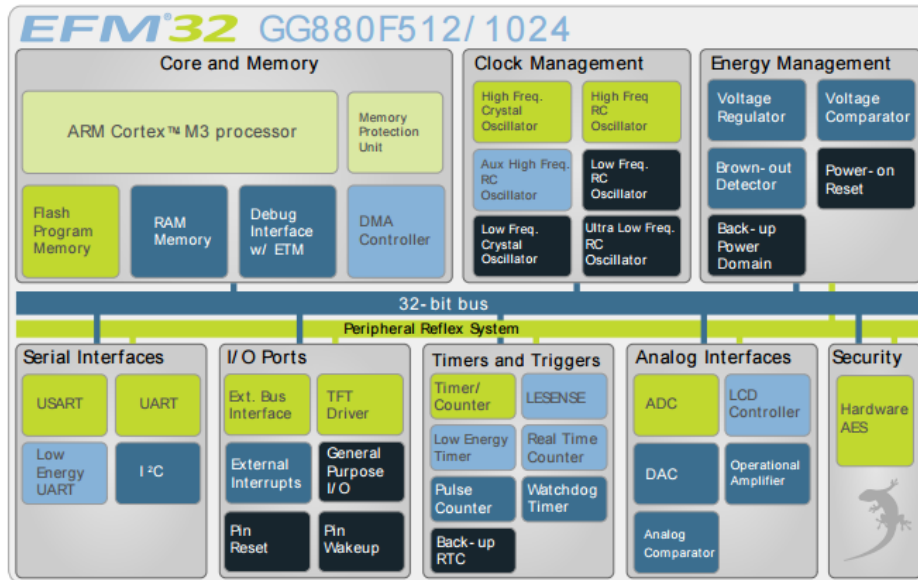

Figure 5 : Block Diagram (Source : <https://www.silabs.com/Support%20Documents/TechnicalDocs/EFM32GG880.pdf>)

We can take the example of EFM32GG880 which are already used in CubeSat project (Cube Sense). In fact, this economic microcontroller energy is an ideal choice for OBC of CubeStats in terms of performance and safety.

Ordering Code	Flash (kB)	RAM (kB)	Max Speed (MHz)	Supply Voltage (V)	Temperature (°C)	Package
EFM32GG880F512-QFP100	512	128	48	1.98 - 3.8	-40 - 85	LQFP100
EFM32GG880F1024-QFP100	1024	128	48	1.98 - 3.8	-40 - 85	LQFP100

Figure 6: the available EFM32GG880 devices (Source : <https://www.silabs.com/Support%20Documents/TechnicalDocs/EFM32GG880.pdf>)

However if we choose this microcontroller we will have to add external memory. In fact, The 128 kB of RAM (random access memory) and 1024 kB flash memory EFM32GG880 are indeed not enough to save all satellite data, as scientific data have been estimated between 1 and 6 MB by measuring scenario.

(Flash memory S29GL512 with 64 MB, Spansion Manufacturer & MRAM MR0A08B of 128kB, Everspin Manufacturer)



### 6.3.3 Proposed OBC architecture

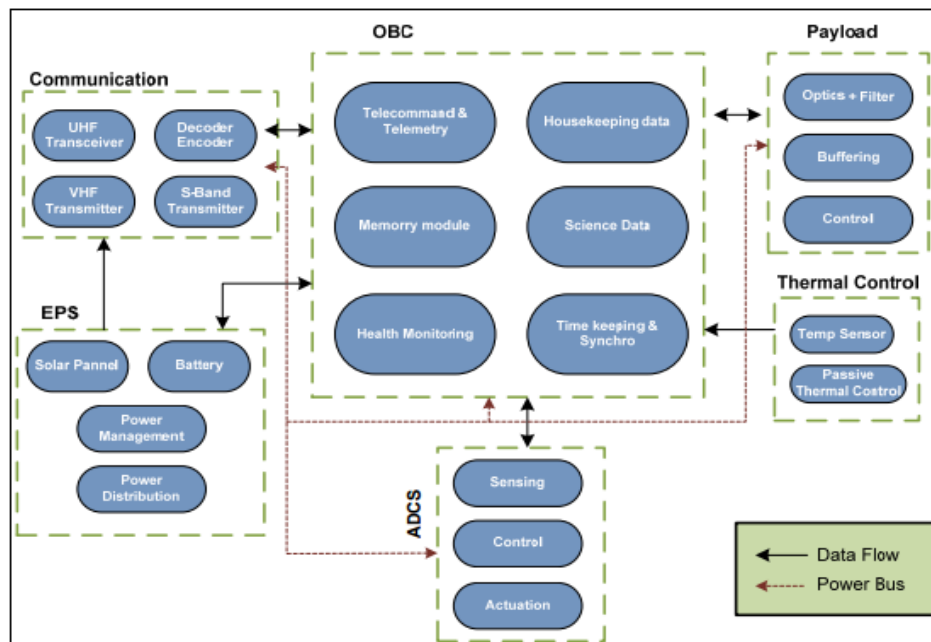

Figure 7: Basic functional diagram of a CubeSat internal organisation (Source: [http://digitalknowledge.cput.ac.za/jspui/bitstream/11189/1307/1/Lumbwe\\_T\\_Final2013.pdf](http://digitalknowledge.cput.ac.za/jspui/bitstream/11189/1307/1/Lumbwe_T_Final2013.pdf))

The OBC architecture is essentially based on the connectivity between subsystems within the CubeSat. This simply means that the microcontroller's peripherals are configured according to the data flow within the CubeSat's computing scheme. An example of the basic functional diagram of the CubeSat's internal organisation is shown in Figure 4 where the direction in which data flows and the power distribution network are clearly shown.